

Prizelawn® CBR IV **COMMERCIAL BROADCAST SPREADER**

MODEL CBR IV
MODEL CBR IVSS

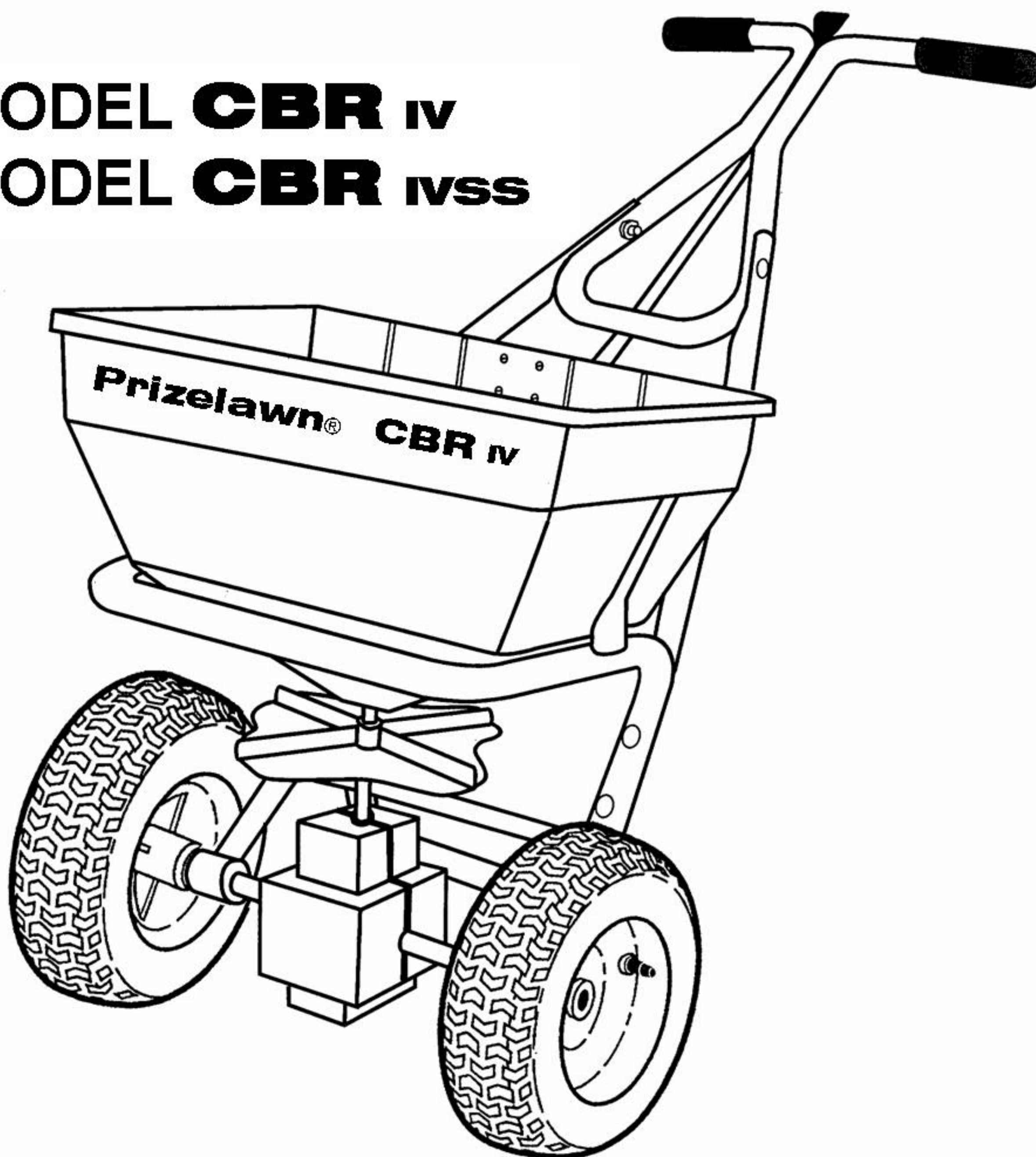

OWNER'S MANUAL

Parts List For Prizelawn® Model CBR IV & CBR IVSS

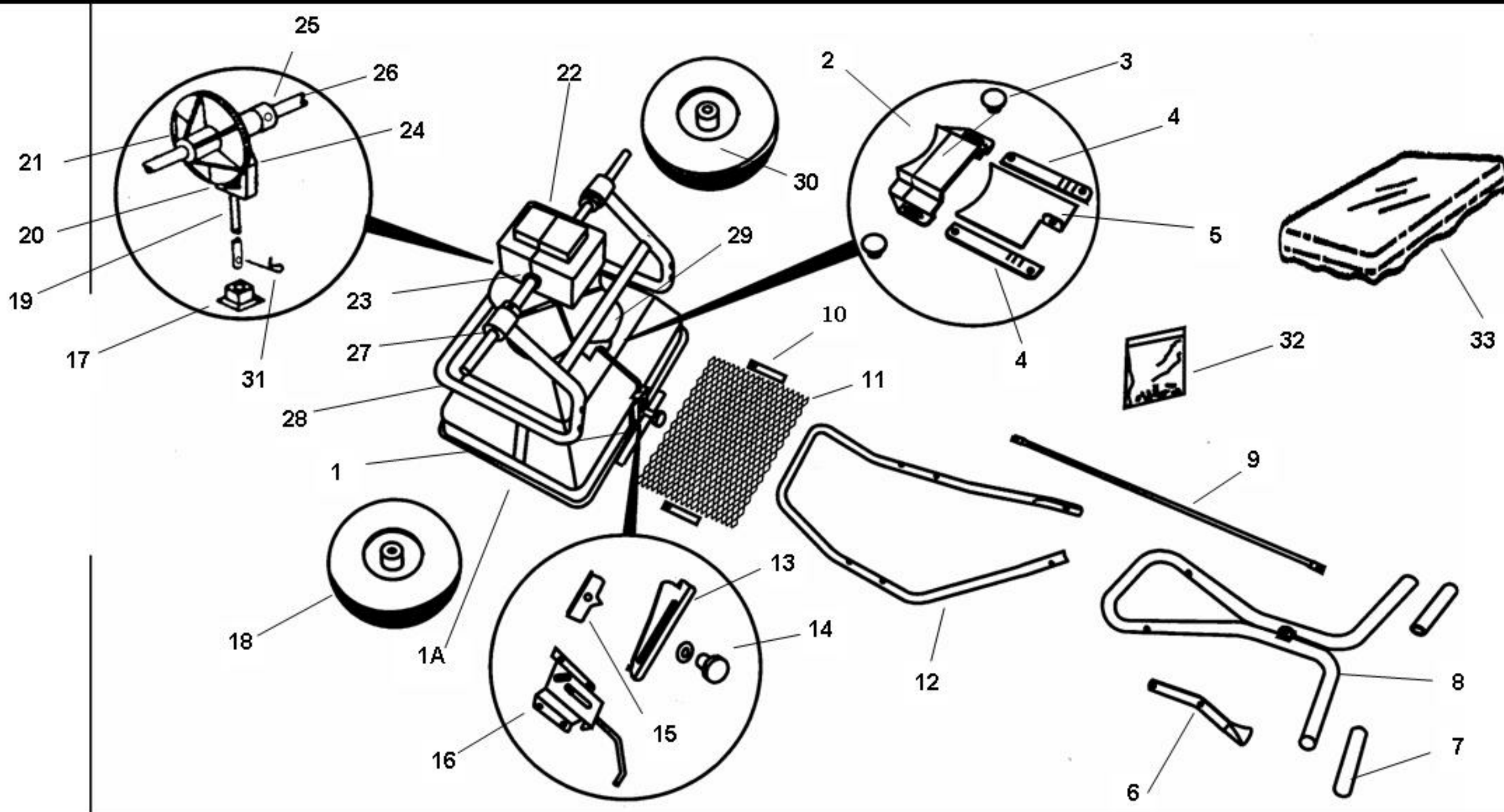

PART OF OUR SERVICE IS PROVIDING REPLACEMENT PARTS. Parts may be obtained through your local distributor. Be sure to give:

1. SPREADER MODEL NUMBER
2. SPREADER NAME
3. PART NUMBER
4. NAME OF PART AS SHOWN



IF YOUR LOCAL DISTRIBUTOR CANNOT SUPPLY PARTS, CONTACT:

PSB Company

555 West Goodale Street P.O. Box 1089
Columbus, Ohio 43216-1089
614-228-5781 EXT. 2655

No.	Description	CBR IV	CBRivss	No	Description	CBR IV	CBRivss
1	Hopper Assembly	15574	15577	17	Impeller Shaft Bearing*	14312-1	14312-1
1A	Hopper*	14604	14604	18	Drive Wheel	14856	14856
2 & 4	Discharge Chute & Shut Off Plate Guides *	15144	15144	19	Impeller Shaft	15036	15036
				20	Pinion Gear	14833	14833
3	Discharge Chute Knob (2)	14001	14001	21	Axle Gear	14832	14832
5	Shutoff Plate*	13353	13353	22	Gear Cover (2)	14837	14837
6	Handle Lever Ass'y	15513	15513	23	Gear Cover Clamps (3)	14868	14868
7	Handle Grip (2)	14870	14870	24	Gear Support	14834	14834
8	Upper Handle	15497	15498	25	Axle Collar w/ Set Scr.	14971	14971
9	Control Tube	14871	14916	26	Axle	15518	15518
10	Screen Clips (2)	14022	14022	27	Axle Bearing (4)	14855	14855
11	Hopper Screen	14603	14603	28	Frame Assembly	15501	15502
12	Handle Brace/Leg	15507	15508	29	Impeller	14625	14625
13	Rate Plate*	15576	15576	30	Free Wheel	14857	14857
14	Rate Control Knob*	12704	12704	31	Agitator	14510	14510
15	Pointer*	12708	12708	32	Fastener Package	15579	15579
16	Spring Housing Assembly*	12702-2	12702-2	33	Hopper Cover	14606-1	14606-1

*Parts included in hopper assembly

CALIBRATION INSTRUCTIONS

The **Prizelawn® CBR IV/CBR IVSS** was factory calibrated, however, calibration should be checked occasionally to assure optimum performance.

1. Pull the on/off lever to the "OFF" position. Set the rate control plate to setting "B".

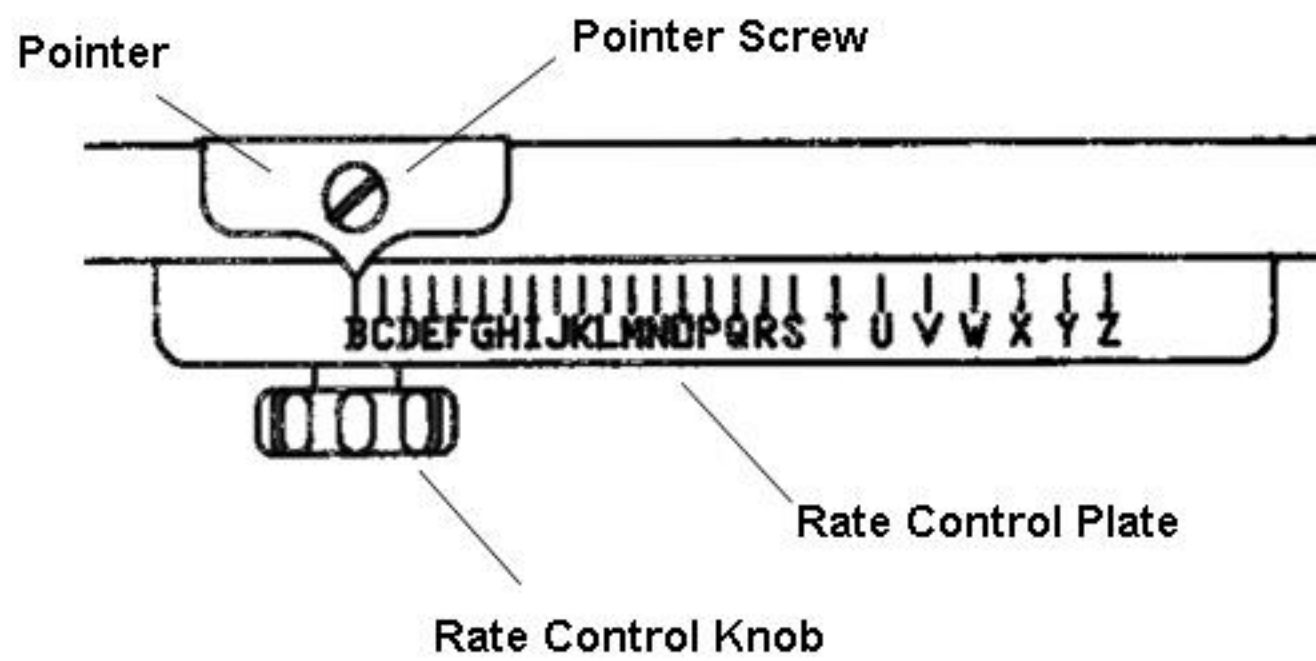

2. Flip on/off control lever to the "ON" position. Check the port opening. It should be just open. If adjustment is necessary, continue to step #3.

3. Loosen the rate control knob and slide the rate plate until the port is just opening. Loosen pointer screw and move pointer until it aligns with "A" on the rate plate. Retighten pointer screw.

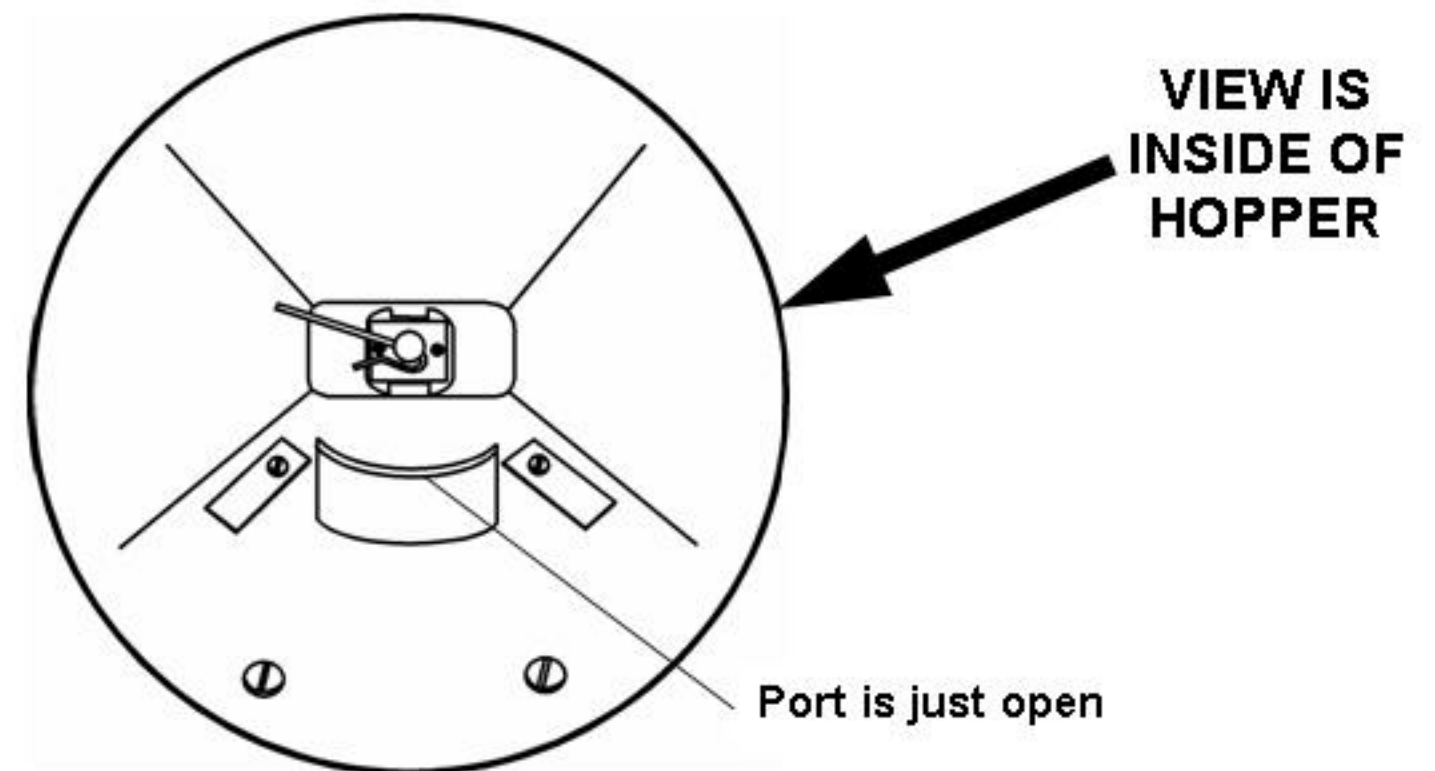

WARRANTY

PSB warrants to Purchaser the following:

1. Product will be free of defects in materials and workmanship for a period of one year from date of purchase.
2. The axle gear, gear support, pinion gear, axle, and axle bearings have a limited lifetime warranty to be free of defects in materials and workmanship.
3. PSB will decide in its reasonable discretion if the part(s)/unit is defective.
4. The spreader or part(s) will be shipped to PSB at the customer expense with a written description of defect to the attention of PSB WARRANTY DEPARTMENT.
5. If the spreader is used for commercial rental the Limited Warranty shall be limited to a period of 90 days.
6. All Unit and part replacement will be performed at the reasonable discretion of PSB.
7. Labor charges are not covered and the unit need not be returned to the dealer for warranty service.
8. Proof of purchase must be supplied to PSB.





PSB's sole obligation under this warranty is limited to repairing or replacing the defective part. Upon replacement of any Product or Product part, the replaced item shall become the property of PSB. If PSB determines that the Product covered by this warranty requires service, PSB shall prepay return shipping charges from PSB. In all other instances, such charges shall be paid by Purchaser. Except for loss or damage caused by PSB's negligence, Purchaser relieves PSB of responsibility for all risks of loss or damage to the Product and its parts during the period the products are in transit to and from PSB.

This warranty does not extend to any Product or parts thereof that have been allowed to corrode, subjected to misuse, neglect, accident, or modification by anyone other than PSB or that have been affixed to any nonstandard accessory attachment or that have been used, stored, installed, maintained or operated in violation of PSB's instructions or standard industry practice. No agent, employee or representative of PSB has any authority to bind PSB to any affirmation, representation or warranty concerning the Product and any affirmation, representation or warranty made by any agent, employee or representative shall not be enforceable by Purchaser.

THIS WARRANTY EXTENDS ONLY TO THE ORIGINAL PURCHASER AND IS EXPRESSLY IN LIEU OF ANY OTHER EXPRESS OR IMPLIED WARRANTIES, INCLUDING WITHOUT LIMITATION ANY IMPLIED WARRANTY OR MERCHANTABILITY OR FITNESS OR INTENDED USE FOR A PARTICULAR PURPOSE AND OF ANY OTHER OBLIGATION ON THE PART OF PSB.

PSB SHALL NOT BE LIABLE FOR ANY INCIDENTAL, SPECIAL OR CONSEQUENTIAL LOSS, DAMAGE OR EXPENSE DIRECTLY OR INDIRECTLY ARISING FROM THE USE OF ANY OF THE PRODUCT INCLUDING, BUT NOT LIMITED TO, DAMAGE OR LOSS OF OTHER PROPERTY OR EQUIPMENT, LOSS OF PROFITS OR REVENUE, COST OF CAPITAL, COST OF PURCHASED OR REPLACEMENT GOODS, OR CLAIMS OF CUSTOMERS OF PURCHASER.

The following provides approximate **Prizelawn® CBR iv/CBR ivss** settings when only the product weight, square foot coverage, and visual inspection of the material is available.

FERTILIZER PARTICLE SIZE	BAG RATE Pounds of fertilizer used per 1,000 sq. ft. of coverage	APPROX. SETTING	SPREAD WIDTH (IN FEET)
Large, heavy particles 	5	M	8
	10	O	8
	15	Q	8
Medium- mixed particles 	5	L	8
	10	N	8
	15	O	8
Small particles (nitrogen) 	1	G	8
	2	J	8
	3	L	8
Mixed size particles -some fines 	5	M	6
	10	O	6
	15	P	6
Light weight particles 	5	J	4
	10	L	To
	15	O	6

The conversions should be used as guidelines for establishing proper rate settings for the particular product being applied. Steps for obtaining the most accurate settings are outlined in the "How to Determine Spreader Settings and Spread Width" section of this manual. These settings are approximate and may vary due to physical characteristics of the product. Walking speed, wear, condition of the turf and humidity, may cause actual rate setting to deviate. No expressed nor implied warranty or guarantee is provided as to coverage or uniformity indicated by these rate settings.

MAINTENANCE

1. Never store unused material in spreader. Return unused product to its original container.
2. Wash spreader thoroughly after each use and dry completely in sun or heated area.
3. Grease axle bearings in frame. Oil the impeller shaft bearing in hopper, pivot points on the shut-off plate and the spring in the housing behind the rate plate.
4. Remove gear cover and wash gears thoroughly. Oil all bearing areas and face of gear teeth. Lubricate gear teeth with dry graphite. Re-install gear cover.
5. Gear mesh should be checked on a regular basis during high use periods. Clearance between the axle gear and pinion gear should be minimal but not tight. If adjustment is necessary, loosen axle collar set screw and hold gears together. Slide axle collar against the gear support and tighten axle collar set screw. Spin drive wheel. Gears should run freely and smoothly.
6. Impeller surface should be cleaned periodically to remove build-up of product. Build-up can cause the spread pattern to change.
7. Tire pressure should be 20-25 PSI.

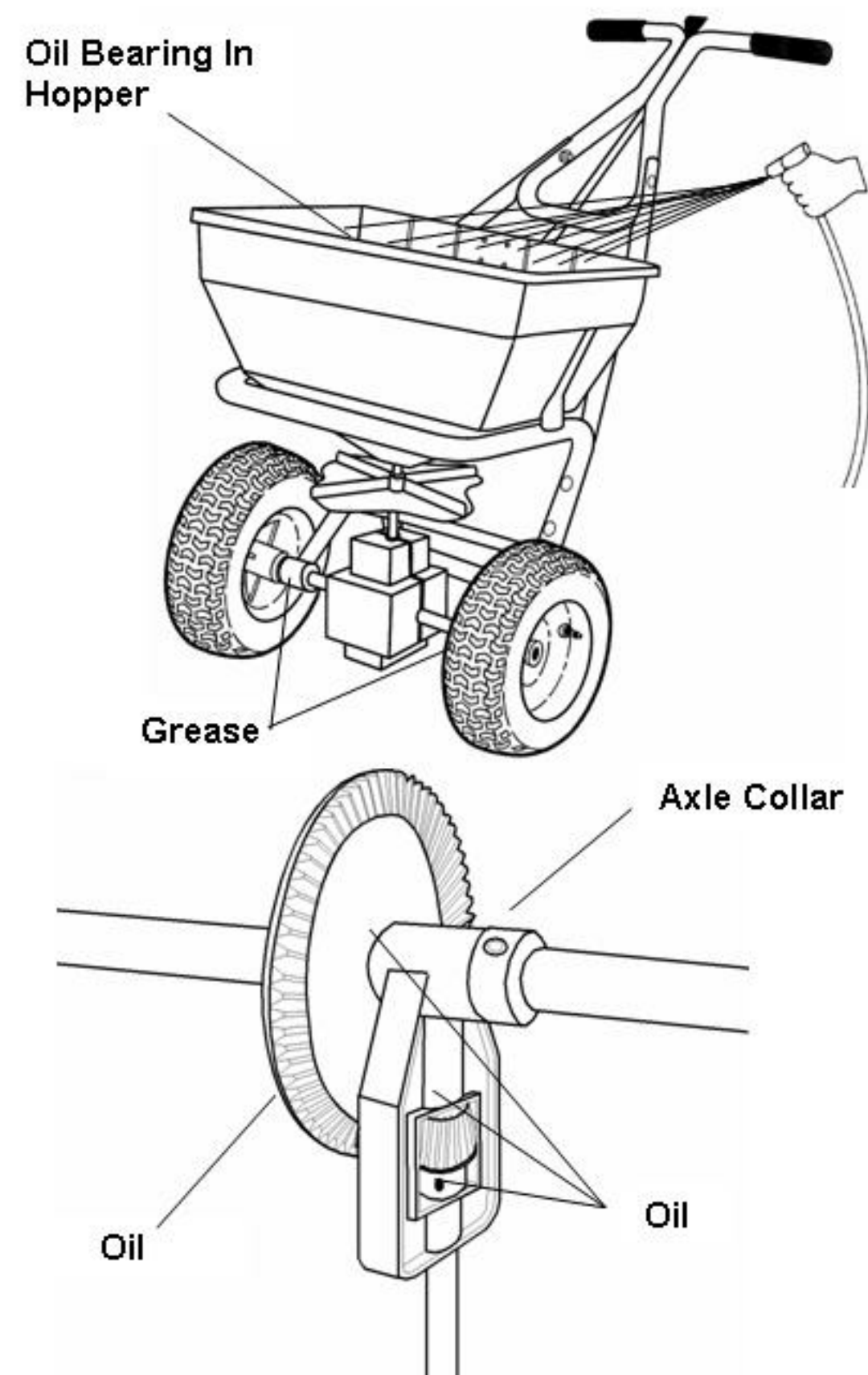

APPLICATION RATE

Knowing the effective pattern width (for example, 10 feet), measure a distance equal to 100 square feet (10' x 10' swath width). Determine the product coverage in pounds / 100 sq. ft. by taking the weight of the product and dividing it by the recommended square foot coverage (add two zeroes to the weight of the bag).

EXAMPLE: Product weight: 25 lbs.
sq. ft. coverage: 5,000 sq. ft.
2500 lbs. - 5,000 sq. ft.
= .5 lbs. / 100 sq. ft.

Weigh out 15 to 20 lbs. of material and spread over the 100 sq. ft. area. Weigh remaining material left in hopper and adjust rate setting as required. Repeat test until application rate is correct.

RATE SETTING CONVERSION

The following provides approximate **Prizelawn® CBR IV/CBR IVSS** settings for those units listed.

Prizelawn. CBR IV Setting	B	C	D	E	F	G	H	I	J	K	L	M	N	O	P	Q	R	S	T	U	V	W	X	Y	Z
Prizelawn. BF I / CBR III Setting	B	C	D	E	F	G	H	I	J	K	L	M	N	O	P	Q	R	S	T	U	V	W	X	Y	Z
Prizelawn. CBR II Setting	—	2	—	2.5	—	3	3.5	—	4	—	4.5	5	5.5	6	6.5	7	8	9.5	10	11	12	13	14	15	—
Lesco #029600 Setting	—	B	C	D	—	E	F	—	G	H	I	—	J	K	L	—	M	N	O	—	P	Q	R	—	S
Scotts R8A/SR-1 Setting	D	E	F	G	H	I	J	K	L	M	N	O	P	Q	R	S	T	U	—	V	W	—	X	Y	Z
Earthway 2200/2400 Setting	5	—	—	—	10	—	—	—	—	15	—	—	—	—	20	—	—	—	—	25	—	—	—	—	30
Spyker 76/78-2 Setting	—	3	—	—	—	4	—	—	5	—	—	6	—	—	7	—	—	8	—	—	—	9	—	—	10
Scotts SPEEDY GREEN	—	—	—	2	—	—	3	3.5	J	4.5	5	5.5	6	—	6.5	—	7	—	7.5	—	8	—	8.5	—	9

PATTERN ADJUSTMENT

Normal spreading of materials requires no adjustment (factory setting "A") unless stated on the package. In those cases where the spread pattern has shifted, the pattern can be adjusted left and right by loosening the two knobs on the discharge chute and moving the chute closer or farther away from the impeller. Settings of "A, B, and C" are provided as reference.

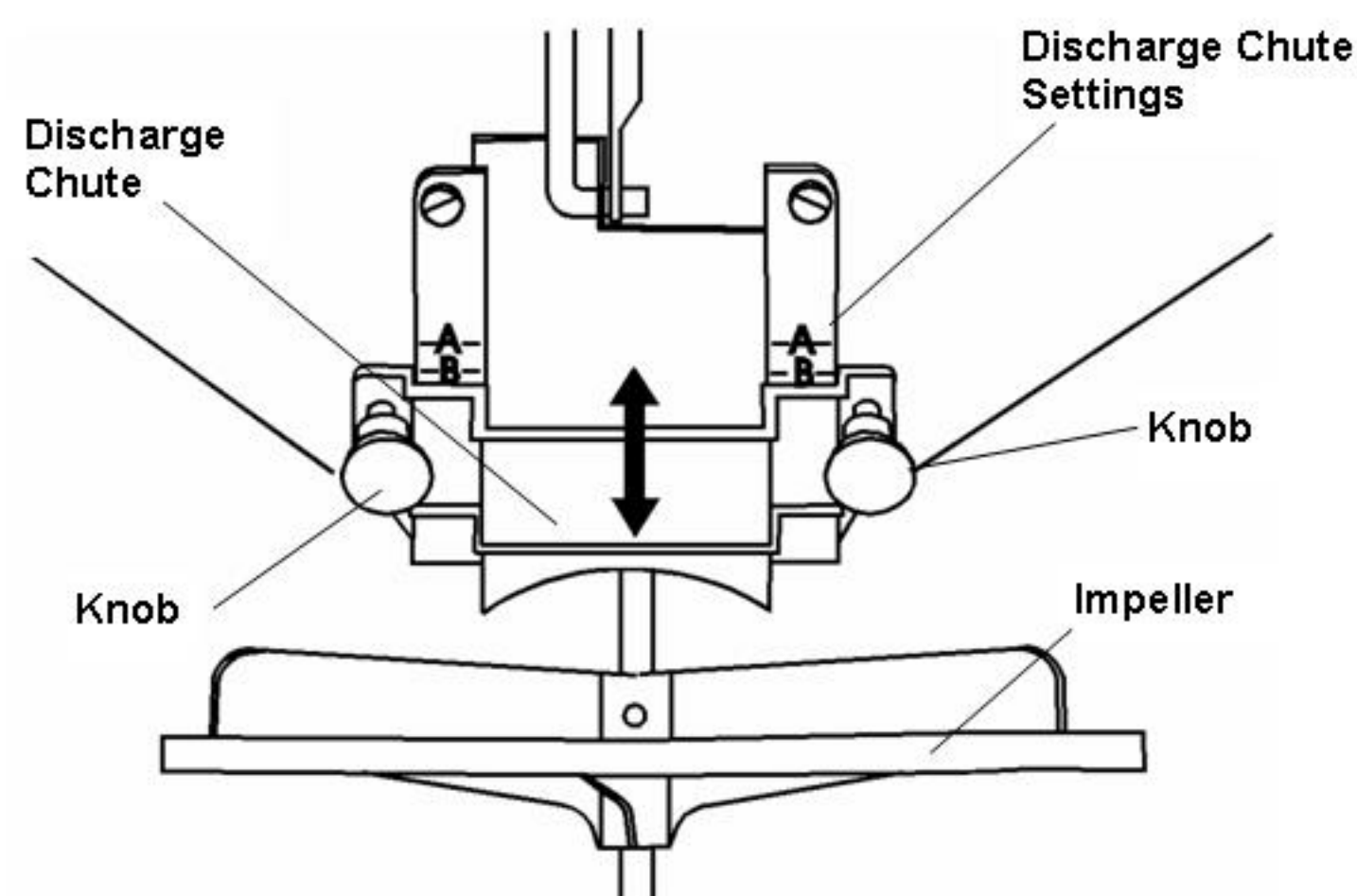

HOW TO DETERMINE SPREADER SETTINGS AND SPREAD WIDTH

Two major factors should be considered when determining correct spreader settings of any product:

1. The product application rate, or the amount of material applied per 1,000 square feet.

2. The effective pattern width, or the actual width in which material is applied. Label settings are a guide and can be affected by numerous factors.

EFFECTIVE PATTERN WIDTH

A simple visual pattern test can be made by operating the spreader over a non-turf area and evaluating the pattern. A more accurate method is to place a row of common, disposable, aluminum cake pans approximately 1 foot on centers. Set the rate plate at a middle setting and make 3 or 4 passes in the same direction as shown. Pour the material collected from each pan into individual bottles of the same size. Set them side by side in order, and visually inspect their volume. If the pattern is not centered (example: volume in bottle #2 left not equal to bottle #2 right), adjust the discharge chute up or down as described in "PATTERN ADJUSTMENT" section.

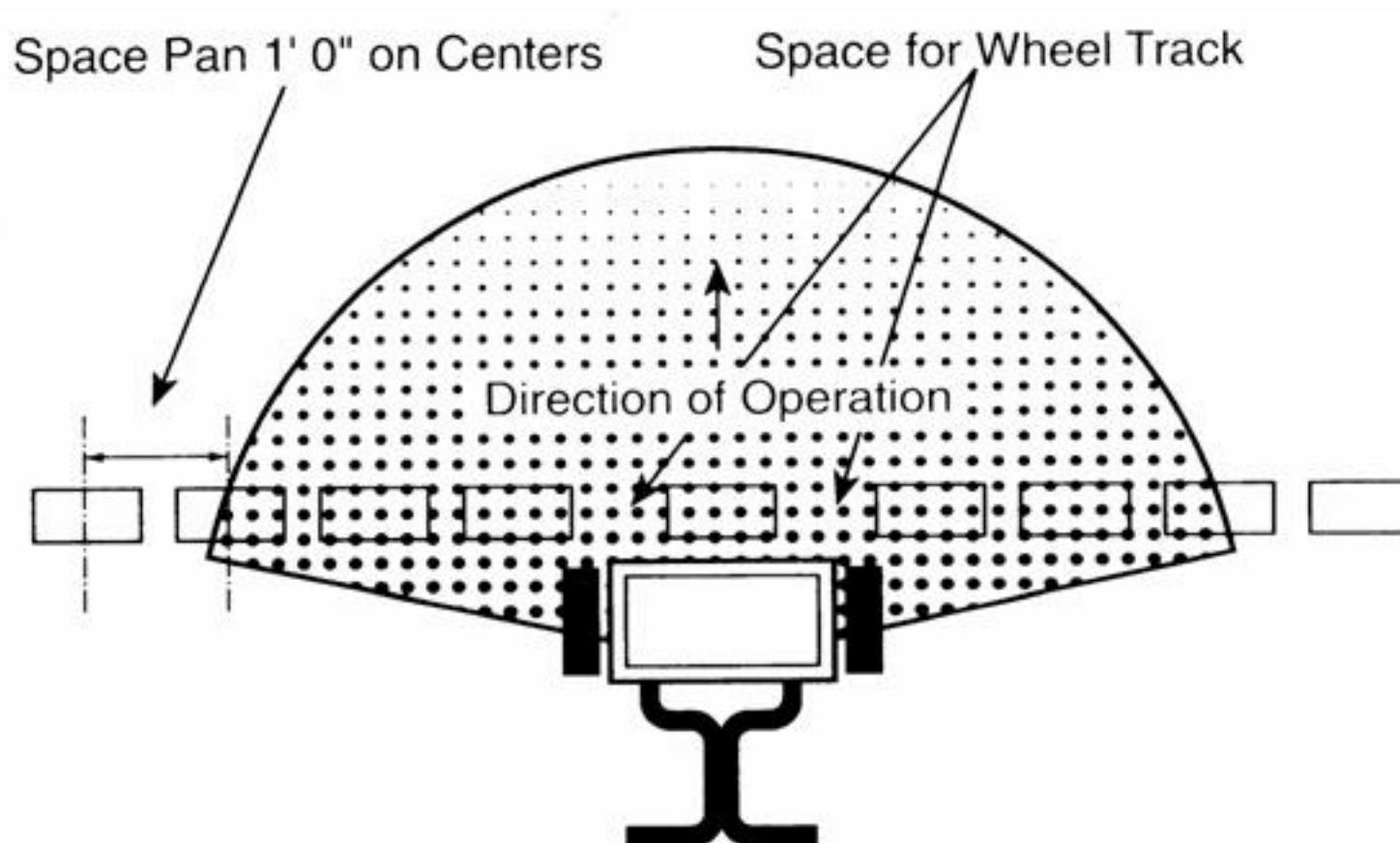

Once the pattern is uniform, the effective pattern width can be determined. The effective pattern width is the distance out from the spreader to a point where the amount of material is $\frac{1}{2}$ the average amount in the center pans. This distance is multiplied by 2 to achieve the total effective pattern width.

4. Install control tube to handle lever with (1) 1/4 dia. clevis pin and a 3/32" dia. cotter pin. Slip opposite end of control tube over lower control rod making sure shutoff plate is between the lower rod and the control tube. Secure with a 3/32" dia. Hitch pin cotter.

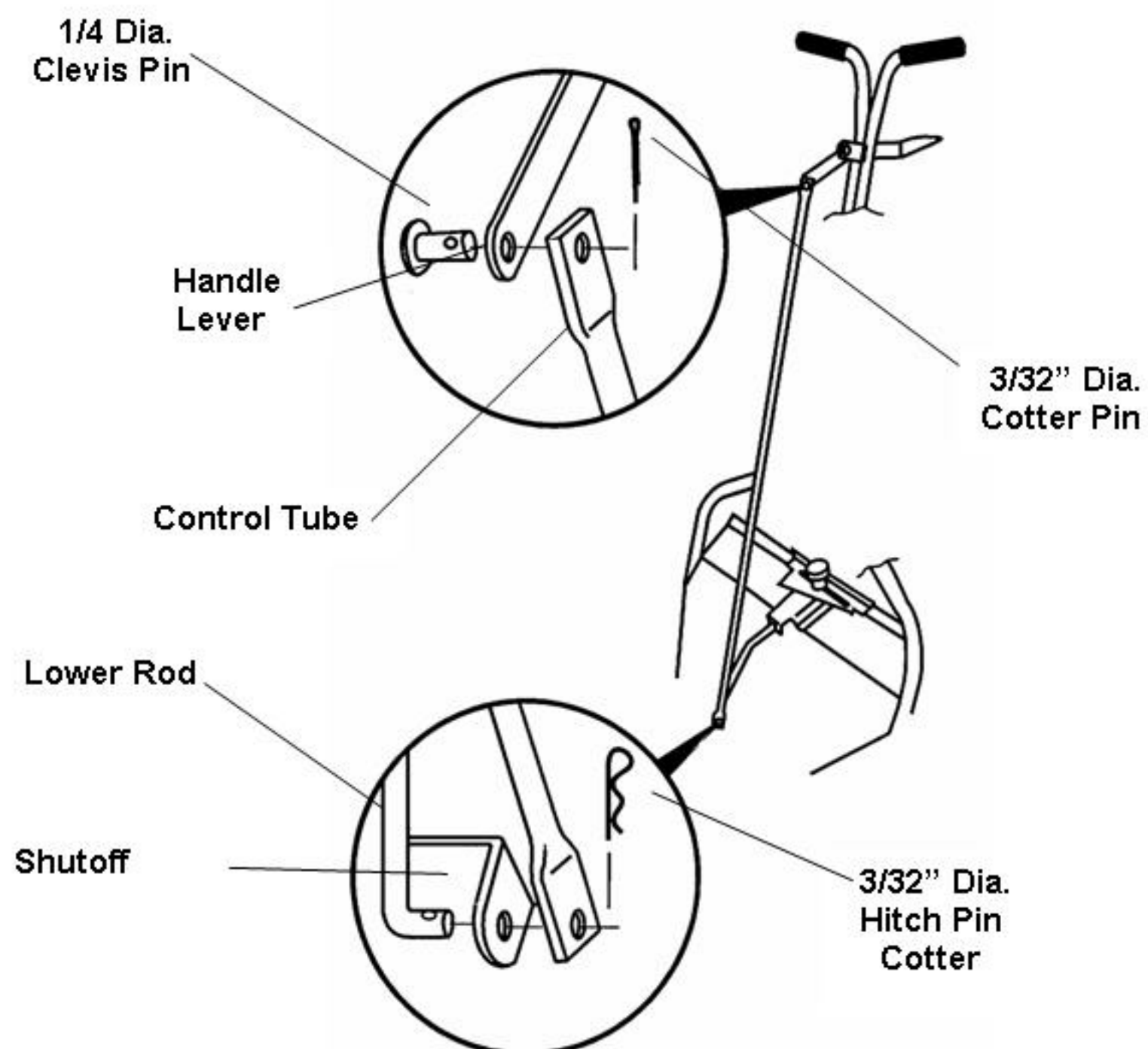

OPERATION

1. Check the product package for the rate setting, and recommended swath width. Loosen rate control knob and slide rate plate to the proper setting. The pattern is controlled by loosening the two knobs on the discharge chute and moving the chute closer or farther away from the impeller (setting A, B, or C). See "PATTERN ADJUSTMENT" for details.

2. Always fill the spreader on the driveway or sidewalk-not on the lawn. Make sure screen is in hopper and spreader is in the "OFF" position.

3. Start spreader moving before opening port. Close before stopping. Always push spreader, never pull.

4. Hold handle so top of spreader is level. Tipping the spreader too far can cause uneven spreading.

5. The settings and swath widths on the product label are recommended starting points. Always check the delivery rate and pattern on a small area before treating a large area. Actual delivery rate can vary due to weather conditions, operating variables, and condition of the product being applied. See "HOW TO DETERMINE SPREADER SETTINGS AND SPREAD WIDTH" for details.

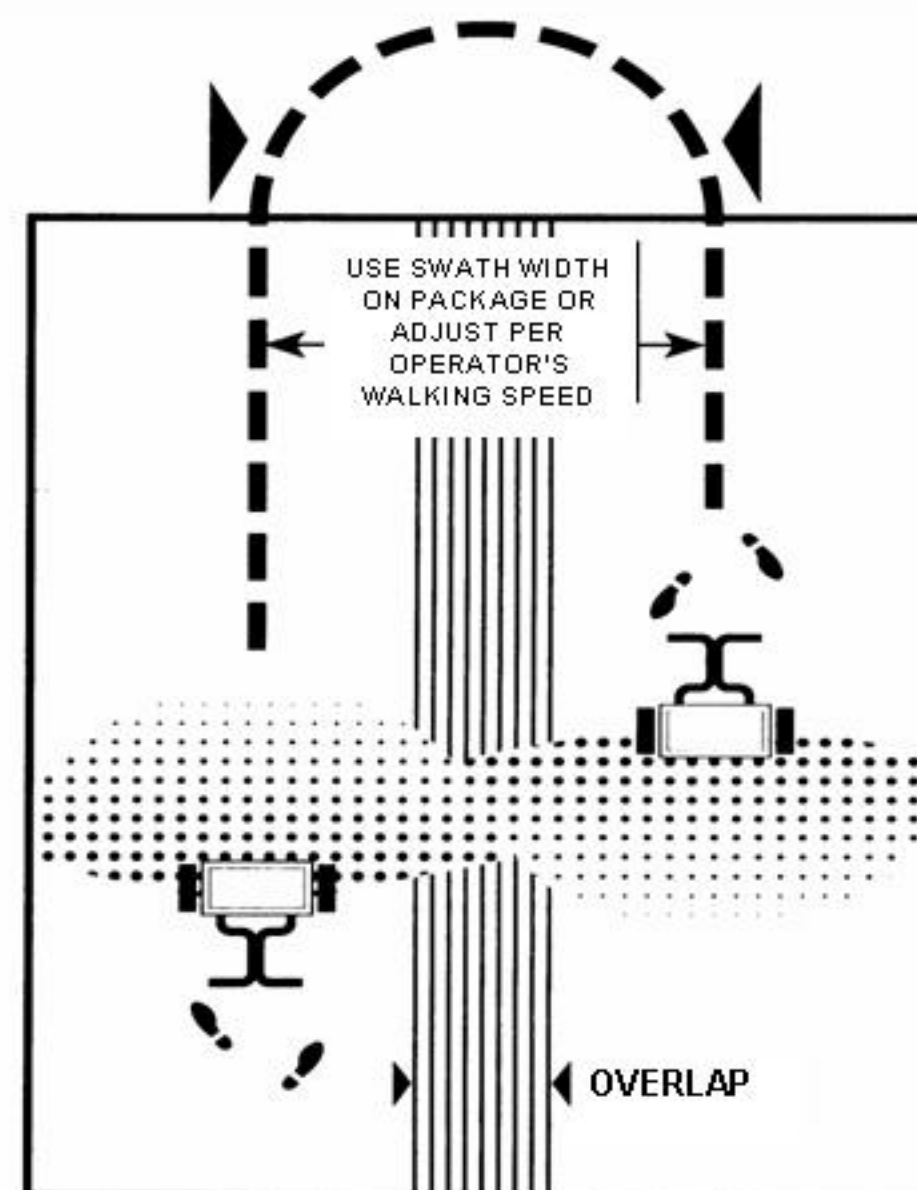

6. Push spreader at a normal walking speed - 2 1/2 m.p.h. (18 feet in 5 seconds). Apply header strips around area to be treated. Space trips across the area as shown. Keep material off flower beds, sidewalks, etc.

7. When transporting spreader, make sure that it is in the "OFF" position.

8. Empty spreader after each use. Return leftover material to its original container.

ASSEMBLY INSTRUCTIONS

1. Remove the spreader and components from carton and place hopper up-side down on a padded surface as shown. Slide drive and free wheel onto axle as shown with the longer portion of wheel hub facing the frame. Secure free wheel with (1) 1/8 dia. x 1 1/4" cotter pin. Attach drive wheel to axle with (1) 3/16 dia. x 2" cotter pin.

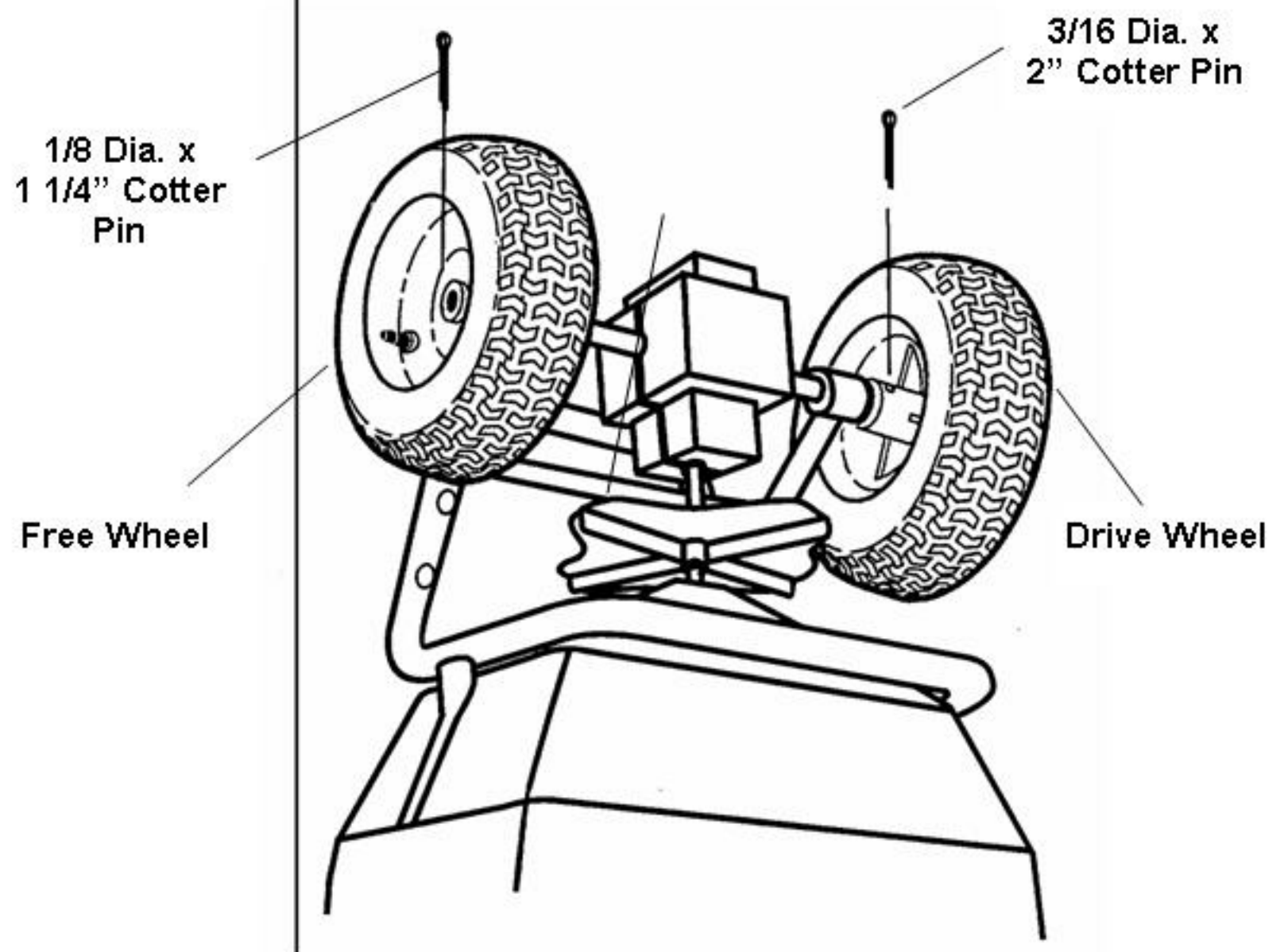

2. Attach leg/brace to frame as shown using (4) 1/4-20 x 2 1/2" carriage bolts and locknuts.

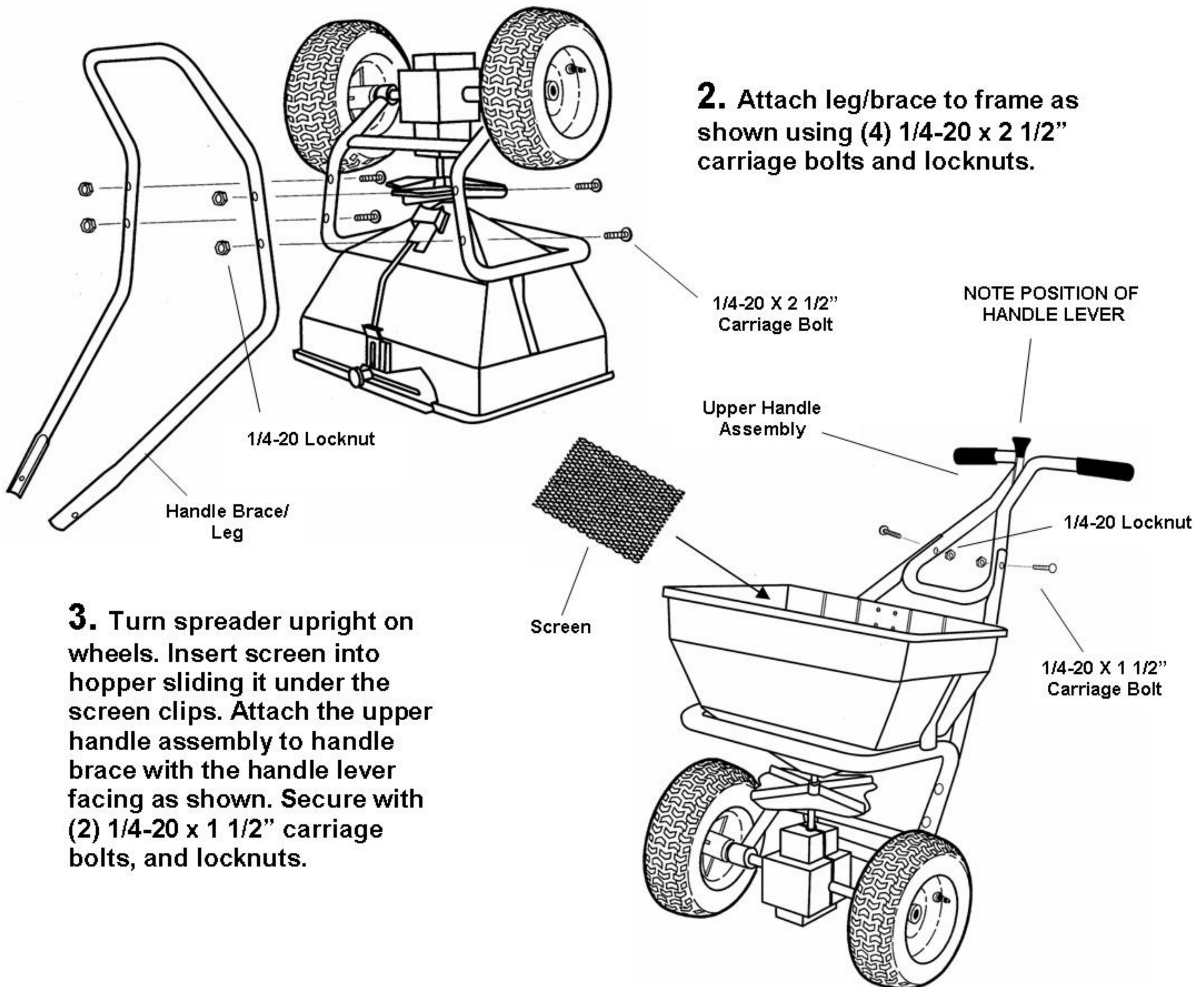

3. Turn spreader upright on wheels. Insert screen into hopper sliding it under the screen clips. Attach the upper handle assembly to handle brace with the handle lever facing as shown. Secure with (2) 1/4-20 x 1 1/2" carriage bolts, and locknuts.